

FACTSHEET - FIFTH AXLE

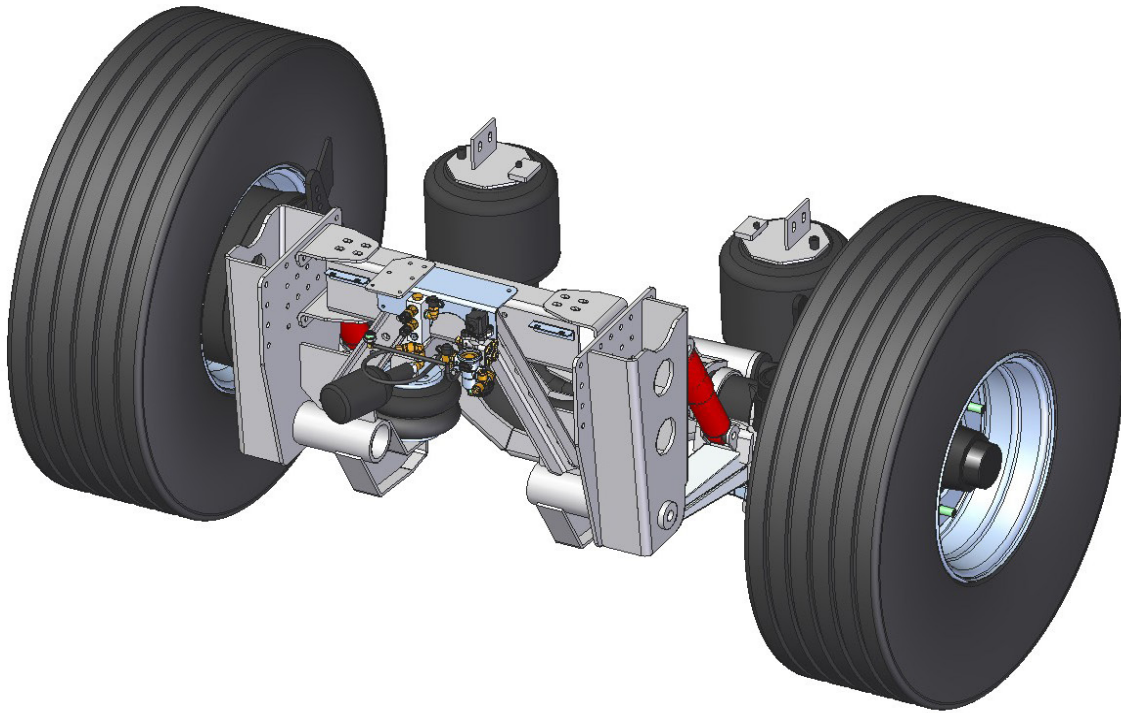

STEERED AND LIFTABLE FIFTH AXLE

The fifth axle increases the payload of the vehicle. It also improves the dynamical anti-roll behavior of the vehicle. The carrying capacity of the axle is load sensed. For better traction the axle is liftable when driving unloaded, which also improves fuel consumption.

SPECIFICATIONS

Capacity	15 tonnes
Brakes	420 mm S-nock Drum
Suspension	Air with lift function
Steering forward	Friction steered with hydraulic stabilizer
Steering rearward	Locked

FEATURES AND BENEFITS

- Increase payload with 20%
- Easy to maintain, no complex electronic systems
- Liftable for additional traction and reduction of fuel consumption